

- NOTES:
1. RESISTANCE VALUES ARE SHOWN IN OHMS UNLESS OTHERWISE NOTED. (K=KILLO OHM, M=MEG OHM)
 2. RESISTOR WATTAGES ARE 1/16W [1005] UNLESS OTHERWISE NOTED.
 3. CAPACITANCE VALUES ARE INDICATED IN MICRO FARADS UNLESS OTHERWISE NOTED. (P=MICRO-MICRO FARAD)
 4. ALL CAPACITORS TEMPERATURE CHARACTERISTICS ARE [CH] (LESS THAN 1000PF) OR [B] (MORE THAN 1000PF) UNLESS OTHERWISE NOTED.
 5. CHIP CAPACITORS TYPE ARE [1005] AND RATED [50V] UNLESS OTHERWISE NOTED.
 6. RESISTOR TOLERANCES ARE [J] UNLESS OTHERWISE NOTED.

DESIGN	DRAWN BY	UNIDEN No.	MODEL No.
'04/12/10	'05/04/10	UB333AH	AE30H
Y. HOSHI	M. KOMA	TITLE KEY ASS'Y	
CHECK BY	APPRO BY	SCHEMATIC DIAGRAM	
		DRAWING No.	
REV. No		UNIDEN CORP.	

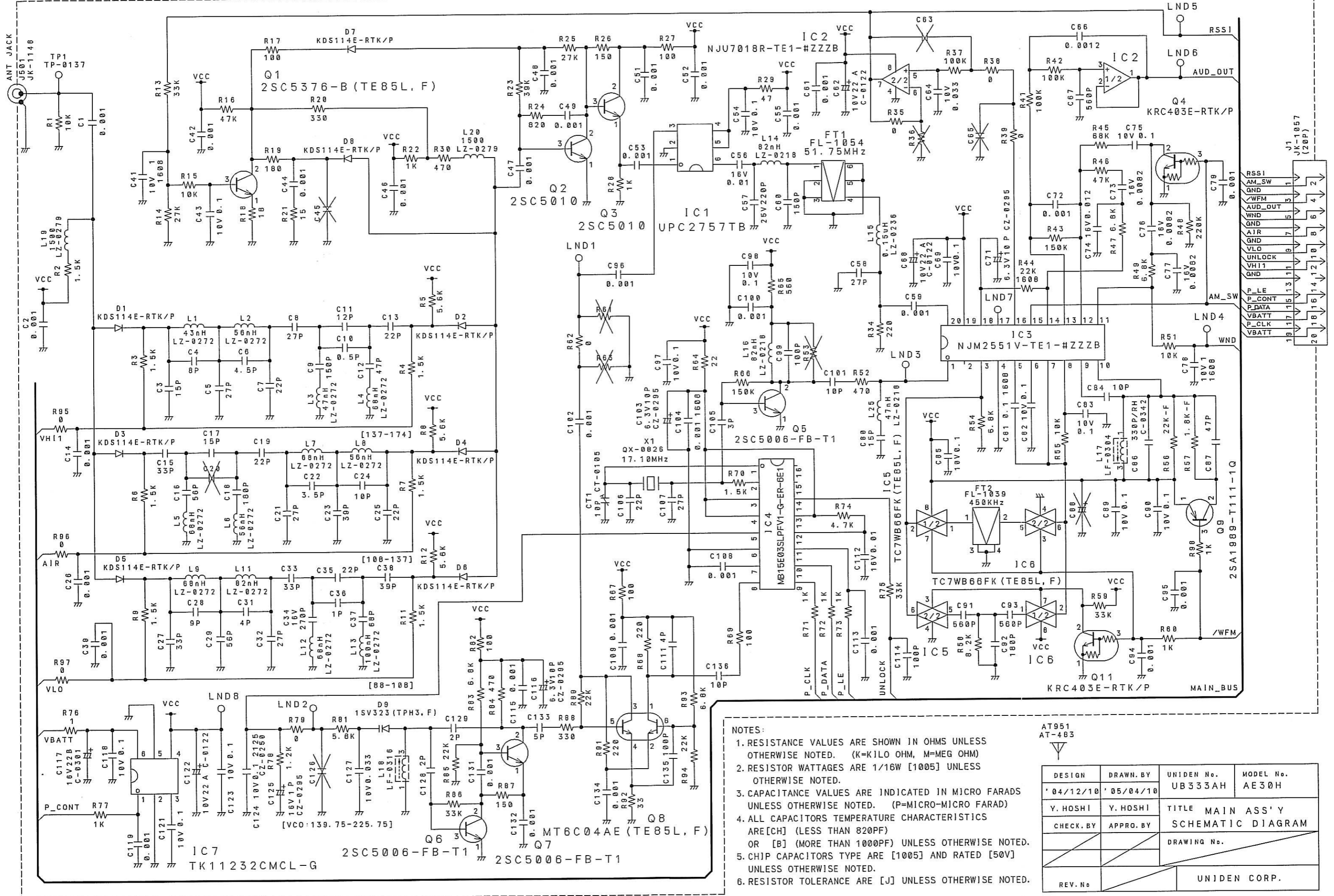

NOTES:

1. RESISTANCE VALUES ARE SHOWN IN OHMS UNLESS OTHERWISE NOTED. (K=KILO OHM, M=MEG OHM)
2. RESISTOR WATTAGES ARE 1/16W [1005] UNLESS OTHERWISE NOTED.
3. CAPACITANCE VALUES ARE INDICATED IN MICRO FARADS UNLESS OTHERWISE NOTED. (P=MICRO-MICRO FARAD)
4. ALL CAPACITORS TEMPERATURE CHARACTERISTICS ARE [CH] (LESS THAN 820PF) OR [B] (MORE THAN 1000PF) UNLESS OTHERWISE NOTED.
5. CHIP CAPACITORS TYPE ARE [1005] AND RATED [50V] UNLESS OTHERWISE NOTED.
6. RESISTOR TOLERANCE ARE [J] UNLESS OTHERWISE NOTED.

AT951
AT-4B3

DESIGN	DRAWN BY	UNIDEN No.	MODEL No.
'04/12/10	'05/04/10	UB333AH	AE30H
Y. HOSHI	Y. HOSHI	TITLE MAIN ASS'Y SCHEMATIC DIAGRAM	
CHECK BY	APPRO BY	DRAWING No.	
REV. No		UNIDEN CORP.	

SPECIFICATION

ISSUED : 2005. 4.10

REVISED:

SCANNING RECEIVER MODEL : AE30H (UB333A)

GENERAL

1. Band Coverage : 7 Bands

2. Frequency Range :

	[Range]	[Step]	[Mode]	
	88.0000 to 107.9000 MHz	100 kHz	WFM	(FM Radio)
	108.0000 to 136.9875 MHz	12.5kHz	AM	(Aircraft Band)
	137.0000 to 143.9950 MHz	5 kHz	FM	(Military Land Mobile)
	144.0000 to 145.9875 MHz	12.5kHz	FM	(2 Meter Amateur Band)
	146.0000 to 155.9900 MHz	10 kHz	FM	(VHF High Band)
	156.0000 to 162.0250 MHz	12.5kHz	FM	(VHF Marine Band)
	162.0300 to 173.9900 MHz	10 kHz	FM	(VHF High Band)

3. Channels : 200 Channels
 40 Channels Search Skip-Memory
 3 Channels Priority Channels

4. Frequency Step : 5/ 6.25/ 8.33/ 10/ 12.5/ 15/ 20/ 25/ 50/ 100 kHz
 /Auto (User-programmable)

5. Display : LCD with Back Light (Color : Orange)

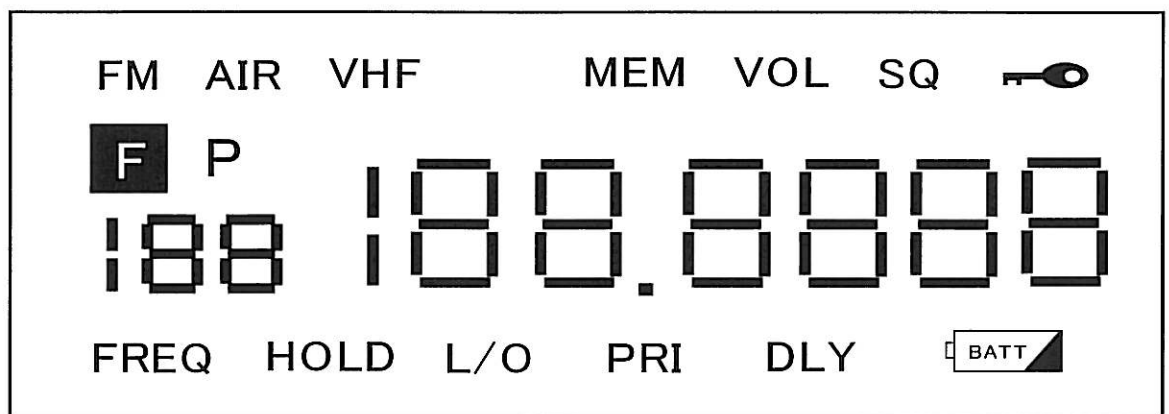

REVISION STATUS

6. Keys : Total 10 Keys

- [FNC] : Set Function Mode
- [F/M] : Select Frequency mode and Memory mode
Writing to Memory Channel (Function Mode)
- [MON] : Set Monitor Mode
Set Key Lock on/off (Function Mode)
- [RSM/HOLD] : Start Scan Mode and Stop Scan Mode (Memory Mode)
Start Search Mode and Stop Search Mode (Frequency Mode)
- [L/O] : Channel Lock Out / Search Skip on/off
Set Priority Function on/off (Function Mode)
- [▲] : Frequency Up (Frequency Mode)
Channel Up (Memory Mode)
Volume Up (Volume Setting Mode)
Squelch Up (Squelch Setting Mode)
Change Frequency Step (Step Mode)
Change Delay Time (Delay Mode)
- [▼] : Frequency Down (Frequency Mode)
Channel Down (Memory Mode)
Volume Down (Volume Setting Mode)
Squelch Down (Squelch Setting Mode)
Change Frequency Step (Step Mode)
Change Delay Time (Delay Mode)
- [VOL/SQ] : Select Volume Setting Mode and Squelch Setting Mode
Set Delay Mode (Function Mode)
- [BAND] : Select Band
Set Frequency Step (Function Mode)
- [PWR] : Power on/off (Hold about 2 seconds)
LCD back light on/off (Function Mode)

7. External Jacks : ANT. Jack : BNC Type
Head Phone Jack : 3.5 ϕ (Stereo Type)

8. Internal Speaker : 24 ohm, 0.8 W Max. (32 ϕ)

9. Power Requirements : 3.6V Provided by 3-AA Size Rechargeable Ni-MH Batteries
(Not included)
or 4.5V Provided by 3-AA size Alkaline Batteries (Not included)

REVISION STATUS

- 10. Batt.Low Indication : A Beep Tone with 15 seconds interval
- 11. Operating TEMP. : -20°C ~ +60°C
- 12. Storage TEMP. : -30°C ~ +60°C
- 13. Size (mm) : 53(W) x 28(D) x 104(H) (Without Antenna)
- 14. Weight : 100 g (without Antenna and Battery)
- 15. Accessories : Rubber Antenna (BNC Type)
Belt Clip
Owner's Manual
- 16. Heterodyne System :
 - 1st Heterodyne
ALL Bands : Upper Heterodyne 1st IF 51.75 MHz
 - 2nd Heterodyne
ALL Bands : Lower Heterodyne 2nd IF 450 kHz
- 17. Filter : 51.750 MHz : SAW Filter
450 kHz : Ceramic Filter (BW±7.5kHz) ; FM/AM

REVISION STATUS

MEASUREMENT CONDITIONS

- 1. Power Source : 4.5V DC at Battery Terminal
- 2. Antenna Impedance : 50 ohm
- 3. Test Temperature : +25 ± 5°C
- 4. Modulation Frequency : 1kHz
- 5. Deviation : FM ± 3 kHz Dev.
WFM ± 22.5 kHz Dev.
AM 60% Modulation
- 6. Mean Signal Input Level : 100 μV
- 7. Audio Output Load : 32 Ω Resistive Load at Jig
- 8. Standard Ref. Audio Output : 0.2 Vrms at Head Phone Jack

<u>ITEM</u>		<u>UNIT</u>	<u>NOMINAL</u>	<u>LIMIT</u>
1. Sensitivity (12dB SINAD)				
	FM Radio Band			
	(WFM) 88.050 MHz	μV	0.9	3.0 Max
	(WFM) 98.550 MHz	μV	0.9	3.0 Max
	(WFM) 107.950 MHz	μV	0.9	3.0 Max
	Aircraft Band			
	(AM) 119.250 MHz	μV	0.4	1.2 Max
	(AM) 127.175 MHz	μV	0.4	1.2 Max
	(AM) 135.500 MHz	μV	0.4	1.2 Max
	VHF High Band			
	(FM) 138.150 MHz	μV	0.3	1.0 Max
	(FM) 162.400 MHz	μV	0.3	1.0 Max
	(FM) 173.225 MHz	μV	0.3	1.0 Max
2. Maximum Sensitivity (for 0.2 Vrms, Vol Max.)				
	(AM) 119.250 MHz	μV	0.2	1.0 Max
	(AM) 127.175 MHz	μV	0.2	1.0 Max
	(AM) 135.500 MHz	μV	0.2	1.0 Max
3. Auto Squelch (Manual)				
	FM Radio Band (WFM) 98.550 MHz	μV	1.4	3.5 Max
	Aircraft Band (AM) 127.175 MHz	μV	0.5	1.5 Max
	VHF High Band (FM) 162.400 MHz	μV	0.3	1.2 Max

REVISION STATUS

<u>ITEM</u>			<u>UNIT</u>	<u>NOMINAL</u>	<u>LIMIT</u>
4. Tight Squelch (Manual)					
FM Radio Band (WFM)	98.550 MHz		μ V	10	15 Max
Aircraft Band (AM)	127.175 MHz		μ V	2	3 Max
VHF High Band (FM)	162.400 MHz		μ V	1	1.5 Max
5. Hum & Noise					
FM Radio Band (WFM)	98.550 MHz		dB	53	40 Min
Aircraft Band (AM)	127.175 MHz		dB	43	35 Min
VHF High Band (FM)	162.400 MHz		dB	39	30 Min
6. Audio Frequency Response - 6dB					
(WFM)	98.550 MHz	Low	Hz	280	150 ~ 400
		High	Hz	1800	1300 ~ 2500
(AM)	127.175 MHz	Low	Hz	260	150 ~ 400
		High	Hz	1800	1300 ~ 2500
(FM)	162.400 MHz	Low	Hz	280	150 ~ 400
		High	Hz	1800	1300 ~ 2500
7. Audio Output Power					
(WFM)	98.550 MHz	Max. Output Power			
		at 32 Ω /Head Phone Jack	mW	20	10 Min
		(at 24 Ω /Int. Speaker	mW	380	200 Min)
(AM)	127.175 MHz	Max. Output Power			
		at 32 Ω /Head Phone Jack	mW	22	10 Min
		(at 24 Ω /Int. Speaker	mW	400	200 Min)
(FM)	162.400 MHz	Max. Output Power			
		at 32 Ω /Head Phone Jack	mW	22	10 Min
		(at 24 Ω /Int. Speaker	mW	400	200 Min)
8. Distortion					
(WFM)	98.550 MHz		%	1.0	3 Max
(AM)	127.175 MHz		%	2.0	6 Max
(FM)	162.400 MHz		%	1.2	5 Max

REVISION STATUS

<u>ITEM</u>	<u>UNIT</u>	<u>NOMINAL</u>	<u>LIMIT</u>
9. Power Consumption at 24Ω Int. Speaker @162.400 MHz (FM), Manual Mode at Squelched	mA DC	36	50 Max
at full output(Light:Off)	mA DC	160	220 Max
at full output(Light:On)	mA DC	180	250 Max
10. Residual Noise @ Vol:Max. SQ:Close (FM) 162.400 MHz	mV	0.3	1 Max
11. Scan Rate at Test Frequency	CH/Sec	25	10 Min
12. Search Rate at Test Frequency (FM) 143.00~144.00MHz	STEP/Sec	25	10 Min
13. Selectivity (FM) 162.400 MHz	-6dB (+) kHz	+8	+5 Min
	(-) kHz	-8	-5 Max
	-50dB (+) kHz	+12.5	+18 Max
	(-) kHz	-12.5	-18 Min
14. IF Rejection (FM) 162.400 MHz (IF=51.750 MHz)	dB	70	40 Min
15. Battery Low turn on voltage	V	3.5	3.3 ~3.7
16. Auto power off voltage (Auto power off voltage < Battery Low turn on voltage)	V	3.4	3.2 ~3.6

REVISION STATUS
